

Limitless applications in economically efficient concrete paving.
**The World of
Wirtgen Slipform Pavers**





Paving concrete the efficient way with innovative Wirtgen machinery.



CUSTOMERS ARE PLACING EVER HIGHER REQUIREMENTS ON STATE-OF-THE-ART SLIPFORM PAVERS IN TERMS OF PERFORMANCE, FLEXIBILITY AND ECONOMIC EFFICIENCY. TO MEET THESE REQUIREMENTS, WE AT WIRTGEN HAVE DEVELOPED SIGNIFICANT PROCESS-RELATED INNOVATIONS WHICH HAVE HELPED WIRTGEN SLIPFORM PAVERS TO GAIN AN EXCELLENT REPUTATION ON A GLOBAL SCALE. THE MARKET LEADERSHIP RESULTING FROM THESE DEVELOPMENTS IS DUE, IN NO SMALL MEASURE, TO OUR CUSTOMERS AROUND THE GLOBE. THEIR CONFIDENCE IN OUR PRODUCTS IS WHAT KEEPS DRIVING US TO EXPAND OUR LEADING POSITION AND TO TREAD NEW PATHS IN THE FUTURE.

CONTENTS

OFFSET PAVERS: ALL-ROUNDERS IN CONCRETE PAVING	6-7
INSET PAVERS: MOBILE ROAD CONSTRUCTION PLANTS	8-9
NUMEROUS INNOVATIONS ON THE ROAD TO GLOBAL PLAYER	10-11
OFFSET SLIPFORM PAVERS IN DETAIL	12-13
INSET SLIPFORM PAVERS IN DETAIL	14-15
DUAL-LAYER CONCRETE PAVING IN DETAIL	16-17
CONCRETE FEEDING TO PERFECTION	18-19
INSERTING STEEL REINFORCEMENT	20-21
PERFECTLY SMOOTH SURFACES	22-23
EFFECTIVE CONCRETE CURING	24-25
INTELLIGENT MACHINE CONTROL SYSTEMS	26-27
PROFESSIONAL EXPERTISE FOR COMPLEX PAVING OPERATIONS	28-29
A WINNING TEAM OF PAVERS COVERING ALL WORKING WIDTHS	30-31
STATE-OF-THE-ART PRODUCTION OF DURABLE MACHINES	32-33
WORLDWIDE CUSTOMER SERVICE MAKES THE DIFFERENCE	34-35
WIRTGEN SLIPFORM PAVERS CONQUER THE WORLD	36-37
WE FACE UP TO THE CHALLENGE OF ENVIRONMENTAL PROTECTION	38-39





Offset pavers: all-rounders in concrete paving

JUST THE RIGHT PAVING MOULD FOR ALL KINDS OF PROFILES

The production of poured-in-place concrete profiles calls for flexible solutions in line with field requirements. Whether standardized or customized profile designs, whether concrete safety barriers, water gutters, kerbs or narrow paths: we at WIRTGEN build made-to-measure paving moulds for each application ensuring that construction projects are completed on time and with economic efficiency. The continuous, compact structures are cast into a homogeneous whole, with or without reinforcement, and are distinctive for their excellent stability, perfect design and ease of maintenance.

In addition, WIRTGEN offset moulds can be mounted on the left or right side of the slip-form paver. This feature optimizes and greatly facilitates logistics on site as the mixer truck can always pull out of and merge back into the flowing traffic quickly and safely in the direction of travel.

Their high degree of stiffness provides concrete safety barriers with superior containment performance levels.





1 |

1 | Complex poured-in-place profiles - such as the kerb and gutter profile shown here - are produced in a single operation.

2 | A virtually limitless range of moulds can be used - profiles can even be poured below road level.

3 | Efficient production of narrow paths in offset application.



2 |



3 |



Concrete roads are exceedingly durable: they have an expected life of at least 30 to 40 years.

Inset pavers: mobile road construction plants

QUICK AND ECONOMICAL PRODUCTION OF CONCRETE PAVEMENTS

Concrete pavements are used in an exceedingly wide range of applications, such as in the construction of motorways, trunk roads, airport runways, container storage areas or railway tracks. These structures are exposed to extremely high loads by heavy goods and high traffic volumes. Concrete pavements are the ideal choice when it comes to withstanding these loads on a long-term basis. In addition, traffic volumes keep increasing continuously on a global scale, making ever-higher demands on concrete roads. Clients therefore

attach paramount importance to evenness, durability and the rapid completion of construction projects.

WIRTGEN inset slipform pavers offer working widths ranging from 1.0 m to 16.0 m and are the perfect candidates for the economically efficient production of concrete pavements. The machines have been designed to meet both international standards and specific customer requirements.



1 | Equipped with four separately steerable, pivoting track units, the SP 94i paves concrete slabs to precision at widths ranging from 3.5 m to 9.5 m.

2 | Concrete is the ideal surfacing in particular for trunk roads exposed to extremely high loads.

3 | The large WIRTGEN slipform pavers have also perfected dual-layer concrete paving.

Numerous innovations on the road to global player

1989

Following the acquisition of a slipform paver manufacturer, WIRTGEN begins engineering and marketing slipform pavers.



1990

The SP 500 is launched as the first machine developed entirely by WIRTGEN.



1991

The SP 1600 is the world's first slipform paver capable of direct dual-layer concrete paving.



1994

The SP 250 is a multi-purpose machine used mainly for offset paving applications.



1999

Featuring two track units per machine only, the SP 1500 L paving train is suitable for dual-layer concrete paving.



2000

The SP 1500 used on motorways and airports can be equipped with dowel bar inserter, tie bar inserter and finishing equipment.



2006

The SP 1200 impresses with a self-loading unit comprising dowel bar inserter, tie bar inserter, oscillating beam and super smoother.



2010

The multipurpose SP 15 and SP 25 slipform pavers set new standards in the efficiency of inset and offset applications.



1990

The SP 850 offers working widths ranging from 2.5 m to 9.0 m.



1997

The TCM 850 enables curing of the freshly paved concrete slabs to optimize their surface finish.



2006

Complementing the SP 250, the compact SP 150 is developed to allow paving of smaller offset profiles.



2013

AutoPilot and Field Rover enable most diverse profile configurations to be paved in a precise, automated process without using stringline.



WIRTGEN SETS IMPORTANT MILESTONES

The history of WIRTGEN's slipform paver division is impressive proof that it is possible to take up an existing technology and successfully develop it to perfection with innovative spirit and creativity.

Following the integration of a company that enjoyed an excellent reputation in the industry, WIRTGEN set numerous forward-thinking milestones which have all contributed significantly to the renewed success of the entire technology. Our many pioneering innovations include, among others, a high degree of process automation, the development of machinery for offset paving and dual-layer concrete paving applications.

In 1989, WIRTGEN became actively involved in the technology by acquiring Belgian slipform paver manufacturer SGME and their technologies. WIRTGEN slipform pavers have meanwhile gained an excellent reputation in the market and are the prime choice where paving concrete to perfection is called for.

Offset slipform pavers in detail

12
13

1 | FULLY MODULAR INSET MOULD SYSTEM

Modular design ensures machine configuration in accordance with site conditions. Adjustable to different working widths. Special profile cross-sections can be implemented.

2 | HIGHLY FLEXIBLE OFFSET MOULD SYSTEM

Concrete feeding system offering various adjustment options. Flexible arrangement of the offset mould on the left or right side, close to or far to one side of the machine frame. Most diverse offset moulds for poured-in-place profiles available for a wide of applications.

9 | MODULAR ADAPTABILITY

Flexible arrangement of the paving mould and track units to ensure full machine utilization.

10 | EASE OF OPERATION

Ergonomically designed operator's platform with self-explanatory operating concept to ensure productive working.

11 | INTELLIGENT TRANSPORT CONCEPT

Compact machine dimensions to ensure ease of transport.



FROM THE MIXER TRUCK RIGHT INTO THE PAVING MOULD

In offset application, mixer trucks deliver the concrete into the receiving hopper of the slipform paver. Transport to the mould is effected via a slewable belt or auger conveyor. Depending on the paver model, the belt conveyor is available in different lengths and in folding design. The auger conveyor is also available in different designs. And whether belt or auger conveyor: all settings, such as conveying speed, angle of incline or position can be made at the mere push of a button. A separate cross-feeding auger offers numerous advantages. The mixer truck can drive right in front of the slipform paver, thus eliminating the need to close off additional traffic lanes. The cross-feeding auger is the ideal solution also whenever larger volumes of concrete are required as a material buffer, for example, when paving in narrow bends where it is not possible for the mixer truck to continue the uninterrupted delivery of concrete to the slipform paver.

3 | HIGH-QUALITY MACHINE MANAGEMENT SYSTEM

High-quality machine management system for maximum operational safety, precise machine functionality and automatic detection of configuration and operation parameters.

4 | STEERING AND DRIVE SYSTEM IN LINE WITH FIELD REQUIREMENTS

Adaptive electronic steering and control system for precise driving behaviour and high-precision concrete paving.

5 | EFFICIENT DIESEL ENGINE CONTROL

Engine management in accordance with performance requirements for low diesel consumption and lowest environmental emissions.

6 | AUTOPILOT - EFFICIENT, STRINGLESS MACHINE CONTROL SYSTEM

Economically efficient machine control system developed by WIRTGEN for precise, stringless concrete paving.

7 | FUTURE-PROOF 3D INTERFACE

Certified standard interface for reliable communication with common 3D systems.

8 | PREMIUM-CLASS CROSS SLOPE CONTROL

Unmatched electronic cross slope control system developed in-house to ensure perfect paving results.



Inset slipform pavers in detail

14
15

2 | SELF-LOADING FEATURE

Hydraulic self-loading module for dowel bar inserter, tie bar inserter and finishing equipment.

3 | LONGITUDINAL JOINT TIE BAR INSERTER

Insertion of longitudinal joint tie bars to prevent concrete slabs from drifting apart.

1 | TELESCOPING MACHINE FRAME

Machine frame telescoping in longitudinal and transverse direction to allow full adjustment to site conditions.

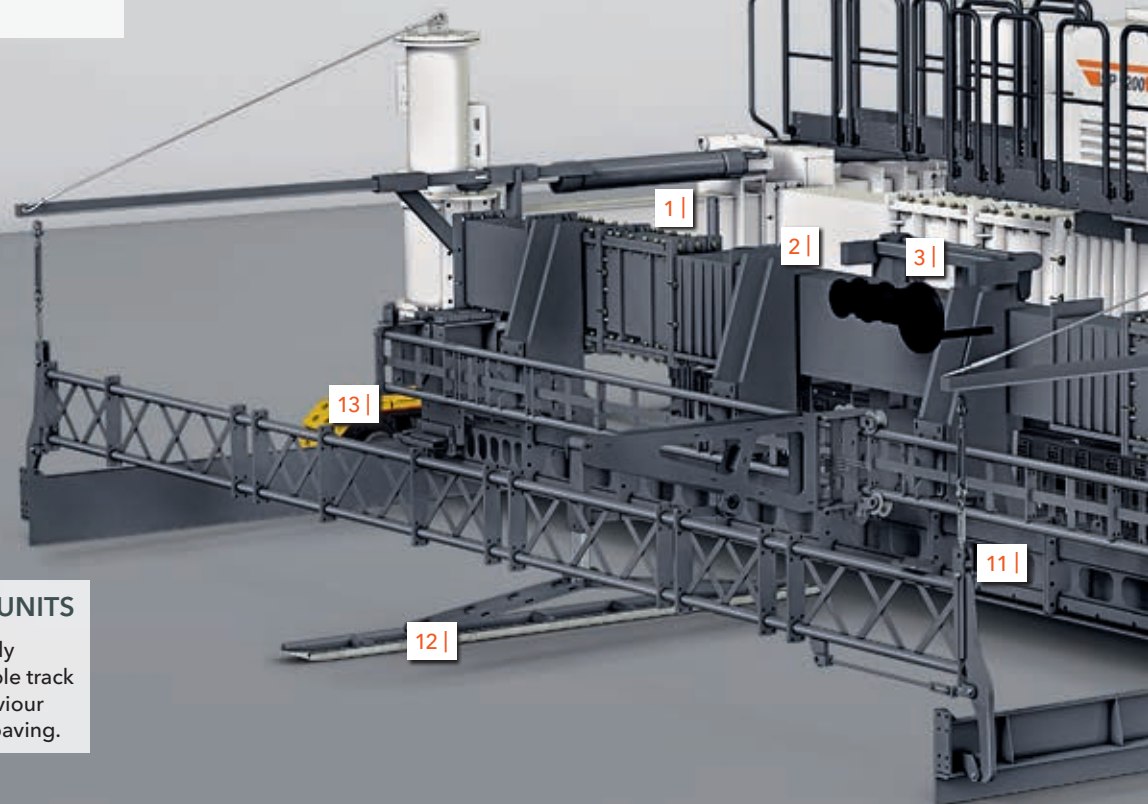

13 | TRACK UNITS

Hydraulically driven, separately height-adjustable and steerable track units for precise driving behaviour and high-precision concrete paving.

12 | SUPER SMOOTHER

Super smoother for a perfectly smooth surface finish.

11 | OSCILLATING BEAM

Eccentrically driven oscillating beam for the removal of surface irregularities.

PAVING BETWEEN THE TRACK UNITS

In inset application, the concrete is either deposited right in front of the slipform paver or is fed in front of the machine from the side via a belt conveyor or side feeder. In the next step, the concrete is distributed evenly across the full paving width by a spreading auger or spreading plough. Homogeneous compaction of the concrete is effected by means of integrated electric or hydraulic vibrators. The inset mould forms the concrete slab to the specified thickness and width while the slipform paver advances. In addition, a dowel bar inserter can be integrated which inserts the dowel bars into the concrete as specified parallel to the paver's direction of travel. Central tie bars or side tie bars can be inserted transverse to the concrete pavement. The surface is levelled off transverse to the paver's direction of travel by the oscillating beam. The "grinding movement" produces a small concrete roll in front of the beam which adds to the high quality of the concrete surface. In the next step, a super smoother is used to finish the concrete slab.

4 | OPERATOR'S PLATFORM

Ergonomically designed, walk-through operator's platform for non-tiring, productive working.

5 | POWER UNIT

High-powered, fuel-efficient diesel engine for concrete paving in the optimum performance and torque ranges.

6 | CONCRETE SPREADING

Spreading plough for even distribution of the freshly delivered concrete in front of the inset paving mould.



7 | VIBRATORS

Electrically driven vibrators for reliable concrete compaction.

8 | INSET PAVING MOULD

Inset paving mould suitable for mounting between the track units, underneath the machine.

10 | SIDE TIE BAR INSERTER

Insertion of side tie bars when paving adjacent concrete slabs.

9 | DOWEL BAR INSERTER

Insertion of dowel bars to maintain the surface levels of neighbouring concrete slabs.

Dual-layer concrete paving in detail

16
17

2 | LONGITUDINAL JOINT TIE BAR INSERTER

Insertion of longitudinal joint tie bars to prevent concrete slabs from drifting apart.

3 | OPERATOR'S PLATFORM

Ergonomically designed, walk-through operator's platform for non-tiring, productive working.

1 | PIVOTING LEGS

Pivoting legs for full adjustment of the track units to the conditions prevailing on site.

17 | CONCRETE SPREADING (TOP-LAYER CONCRETE)

Spreading auger for even distribution of the freshly delivered top-layer concrete in front of the inset paving mould.

16 | VIBRATORS (TOP-LAYER CONCRETE)

Special, electrically driven vibrators for reliable compaction of the top-layer concrete.

15 | INSET PAVING MOULD (TOP-LAYER CONCRETE)

Inset paving mould suitable for mounting between the track units, underneath the machine.

14 | SUPER SMOOTHER

Super smoother for a perfectly smooth surface finish.

13 | OSCILLATING BEAM

Eccentrically driven oscillating beam for the removal of surface irregularities.

12 | TRACK UNITS

Hydraulically driven, separately height-adjustable and steerable track units for precise driving behaviour and high-precision concrete paving.

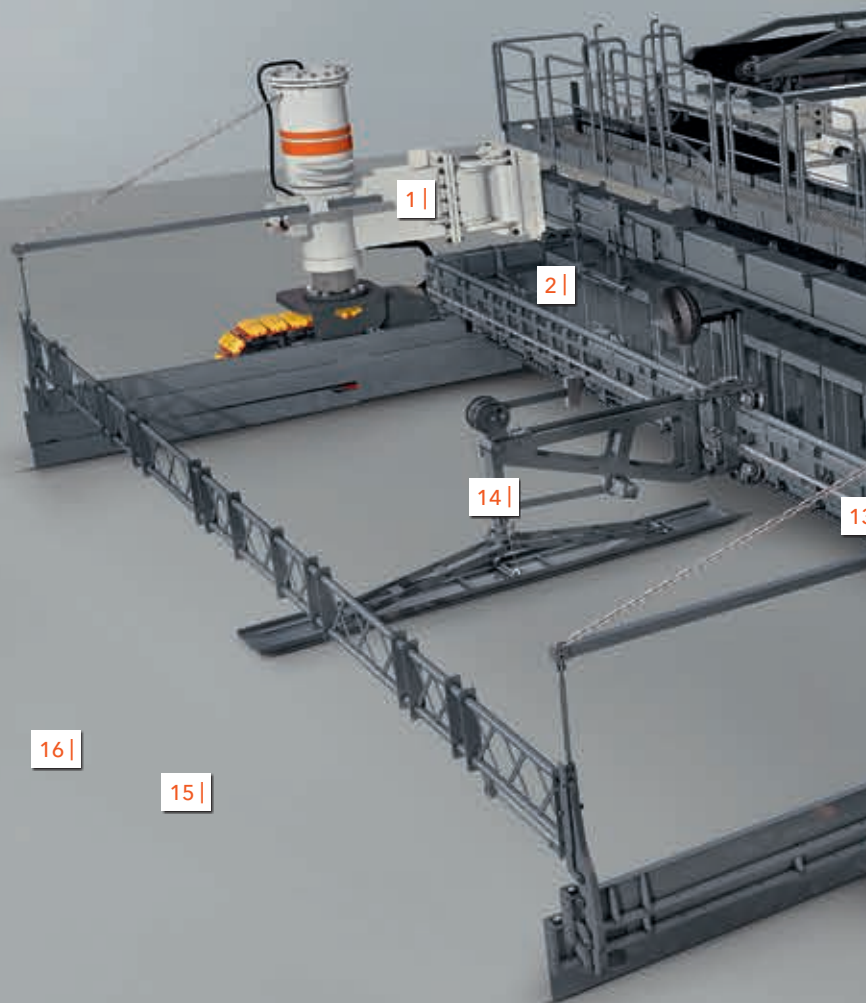

DUAL-LAYER CONCRETE PAVING IN A SINGLE OPERATION

With a single paver (SP 1600): where a single machine is used for dual-layer concrete paving, the bottom-layer concrete and top-layer concrete are paved in a synchronous operation. It is additionally ensured that the bottom-layer and top-layer concrete are paved "wet-in-wet" regardless of weather or site conditions.

With two pavers (SP 1500/SP 1500 L): where two machines are used for dual-layer concrete paving, the bottom-layer concrete and top-layer concrete are paved by two separate slipform pavers. Coordinating the synchronous operation of both machines to ensure "wet-in-wet" paving is substantially more demanding in this type of application. The main advantage of using two slipform pavers is weight distribution. It may be important for the procedures on site to distribute the total operating weight to two separate machines.

4 |

POWER UNIT

High-powered, fuel-efficient diesel engine for concrete paving in the optimum performance and torque ranges.

5 |

CONVEYING SYSTEM

Conveying system transporting the top-layer concrete in front of the top-layer concrete paver.

6 |

CONCRETE SPREADING (BOTTOM-LAYER CONCRETE)

Spreading plough for even distribution of the freshly delivered bottom-layer concrete in front of the inset paving mould.

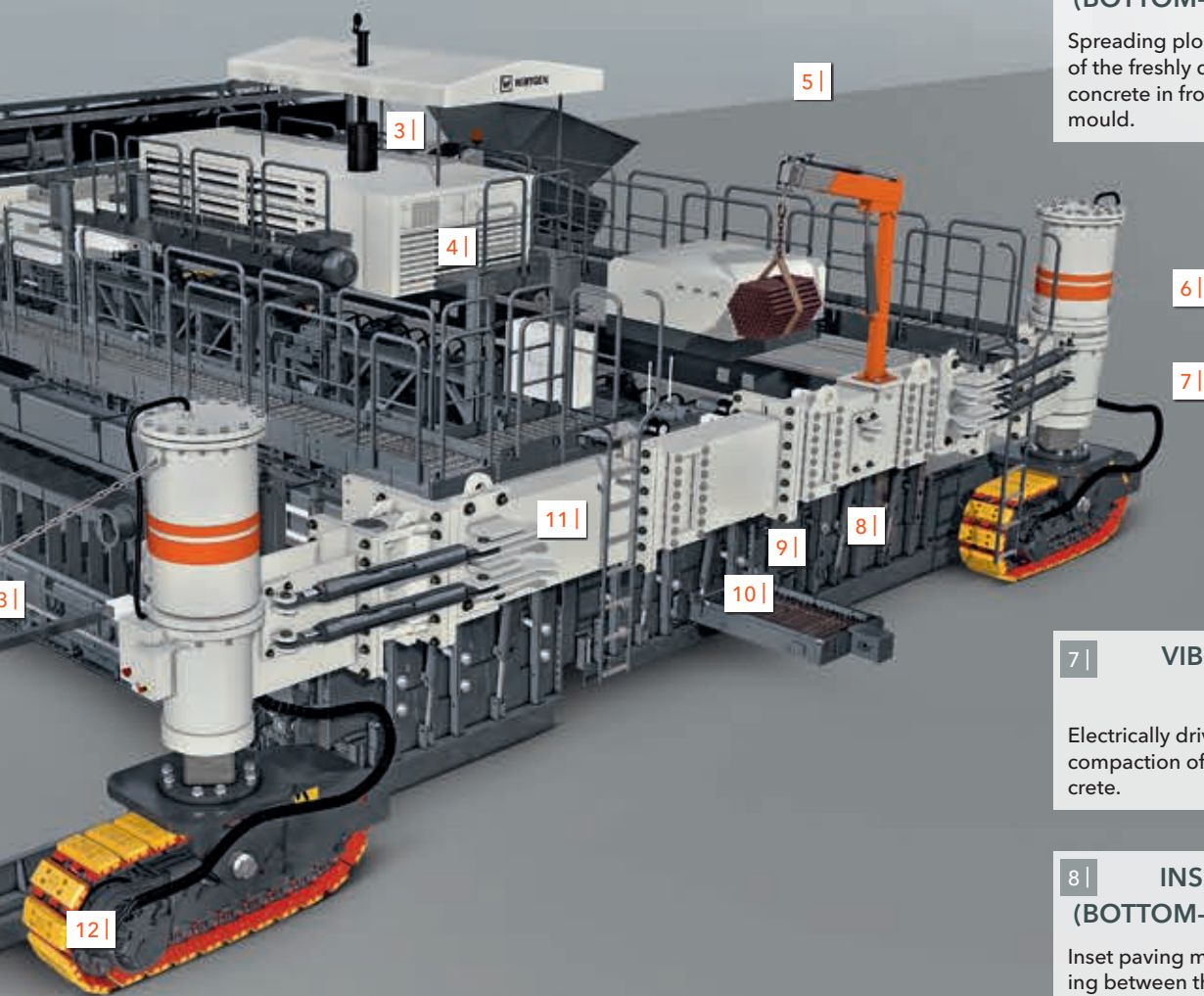

6 |

7 |

7 |

VIBRATORS (BOTTOM-LAYER CONCRETE)

Electrically driven vibrators for reliable compaction of the bottom-layer concrete.

8 |

INSET PAVING MOULD (BOTTOM-LAYER CONCRETE)

Inset paving mould suitable for mounting between the track units, underneath the machine.

11 |

TELESCOPING MACHINE FRAME

Machine frame telescoping to one side in transverse direction to allow full adjustment to site conditions.

10 |

DOWEL BAR INSERTER

Insertion of dowel bars to maintain the surface levels of neighbouring concrete slabs.

9 |

SIDE TIE BAR INSERTER

Insertion of side tie bars when paving adjacent concrete slabs.

Concrete feeding to perfection

TRIED-AND-TESTED SOLUTIONS

1-2 | *Inset application: spreading the concrete by means of a spreading auger or spreading plough.*

Offset applications

We offer different concrete feeding options in accordance with the size and position of the

paving mould, volume and consistency of the concrete to be paved:

- > Standard belt conveyors of different lengths
- > Folding belt conveyor
- > Auger conveyors in different designs
- > Cross-feeding auger

Inset applications

Efficient concrete spreading solutions in line with field requirements are available also for the paving of concrete slabs:

- > Single-piece spreading auger
- > Two-piece spreading auger - required when paving a central crown
- > Spreading plough





3-4 | In offset application, the freshly delivered concrete is transported into the paving mould by means of a belt or auger conveyor.

5 | The hydraulically adjustable cross-feeding auger is capable of feeding concrete to the left or right.



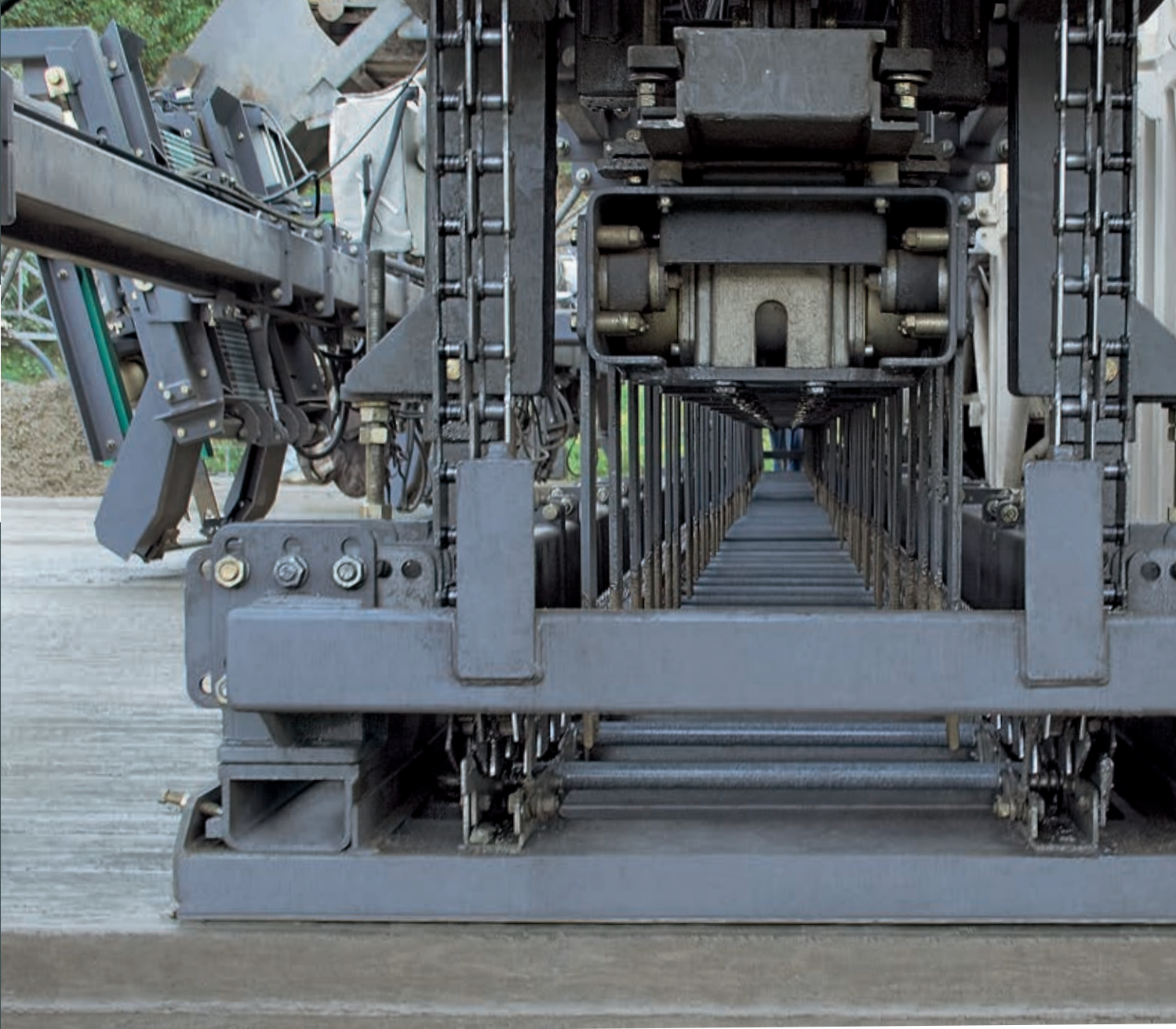

Distribution of the dowel bars by means of an intelligently designed chain system.

Inserting steel reinforcement

CONCRETE ARMoured WITH HIGH-TECH

WIRTGEN has numerous years of international experience in the use of dowel bar and tie bar inserters. WIRTGEN slipform pavers do not stop but keep moving forward continuously while inserting the dowel bars or tie bars. This offers a significant advantage in that the evenness of the concrete slab produced meets the highest requirements.

To prevent uncontrolled cracking of the concrete, the dowel bars inserted in the direction of travel need to precisely comply with both the surface levels and parallel arrangement to the surface and edge of the concrete slab. The integrated dowel bar inserter fully meets

these requirements, thus making a significant contribution to achieving the intended design life of the concrete pavement. Tie bar inserters are installed either to the side of or inside the paver. If installed inside the paver, different arrangements are possible using one or several tie bar inserters. The tie bars inserted reliably prevent concrete slabs from drifting apart in the area of the longitudinal joints.

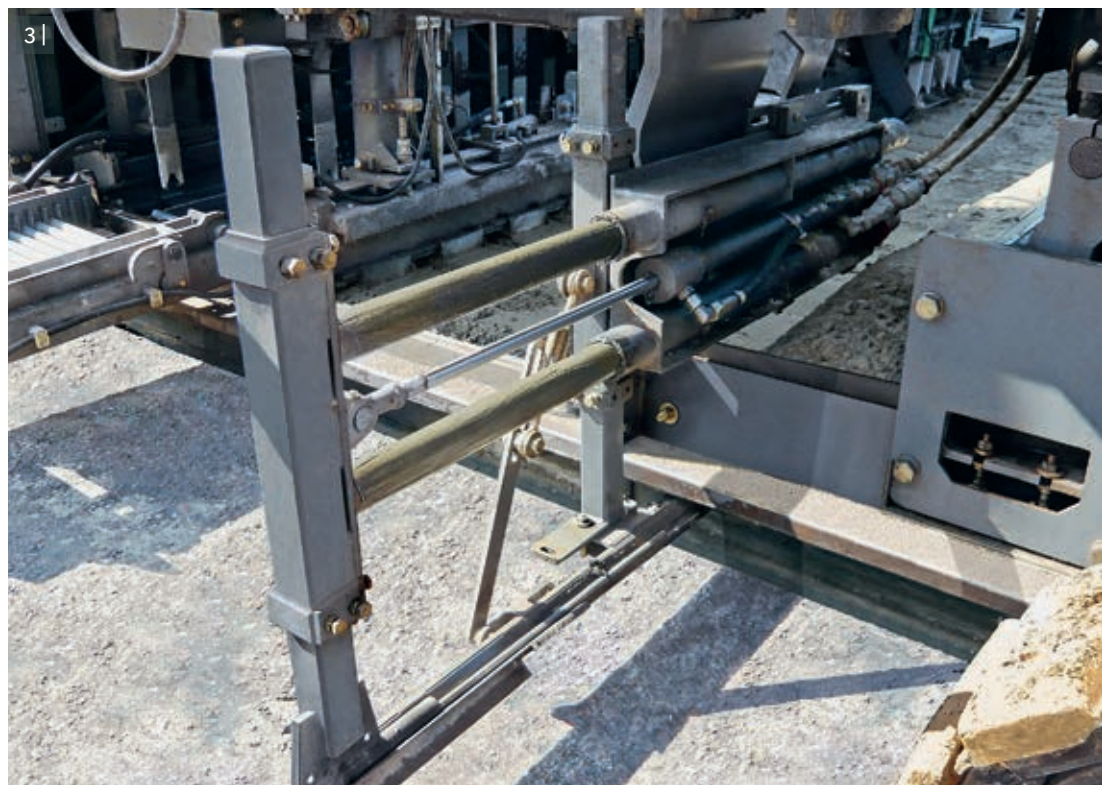
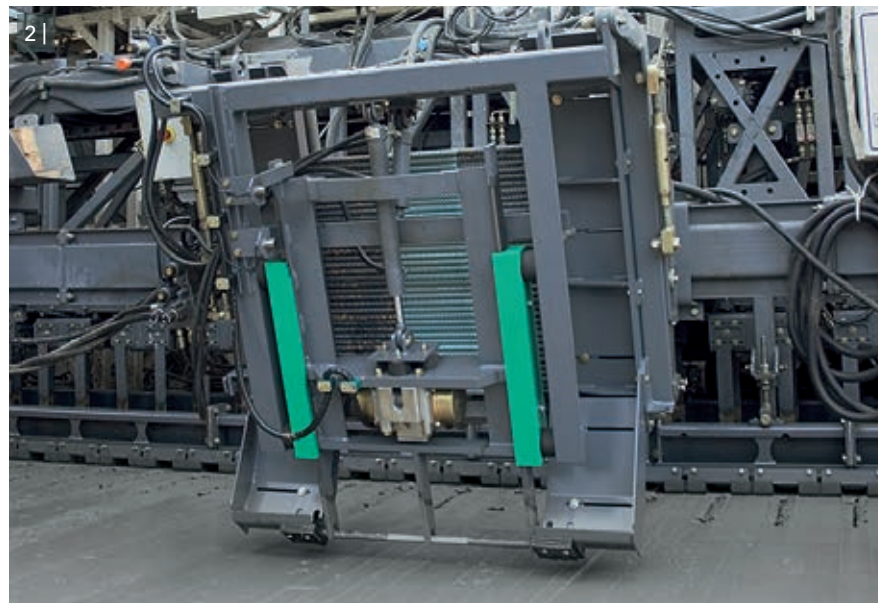
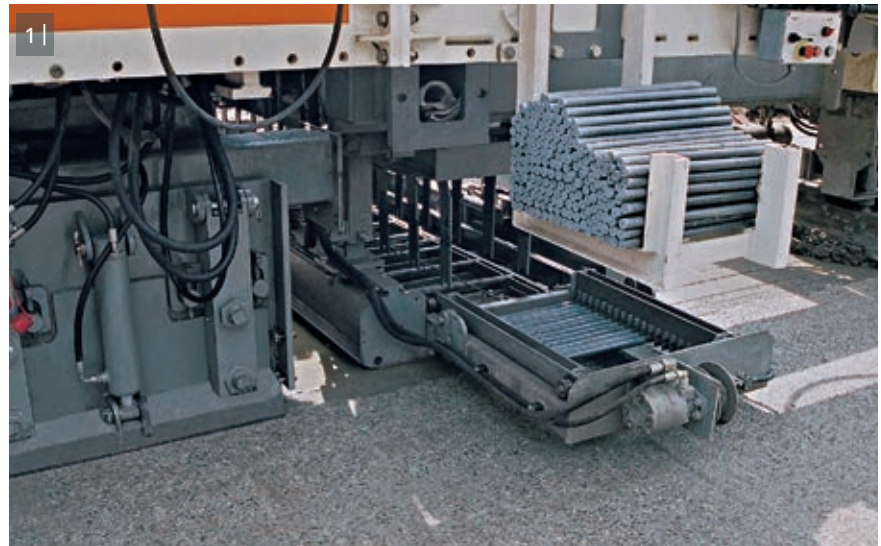

1 | The coated dowel bars are inserted to prevent differences in the level of neighbouring concrete slabs.

2 | Inserting the dowel bars into the concrete.

3 | The side tie bar inserter inserts tie bars in the side of the concrete slab.

Perfectly smooth surfaces

PERFECT EVENNESS FOR EXCELLENT RIDING COMFORT

We rely on numerous technical refinements to achieve this goal. The heavy-duty, torsion-resistant machine main frame makes a significant contribution to producing the required evenness of the concrete surface. The torsion-resistant frame of the inset paving mould prevents irregularities in the concrete slab in the event of varying concrete consistency. The heavy-duty oscillating beam gives the concrete slab an even surface. The super smoother, which is manufactured from high-quality material, then creates the final surface even-

ness by performing an oscillating, combined longitudinal and transverse movement.

Level and steering parameters are communicated to the WIRTGEN machine control system via the stringline or intelligent 3D interface.

The interaction between the fully engineered WIRTGEN machine technology, equipment configurations tailored to requirements and specified concrete quality produces a concrete slab of perfect surface evenness.



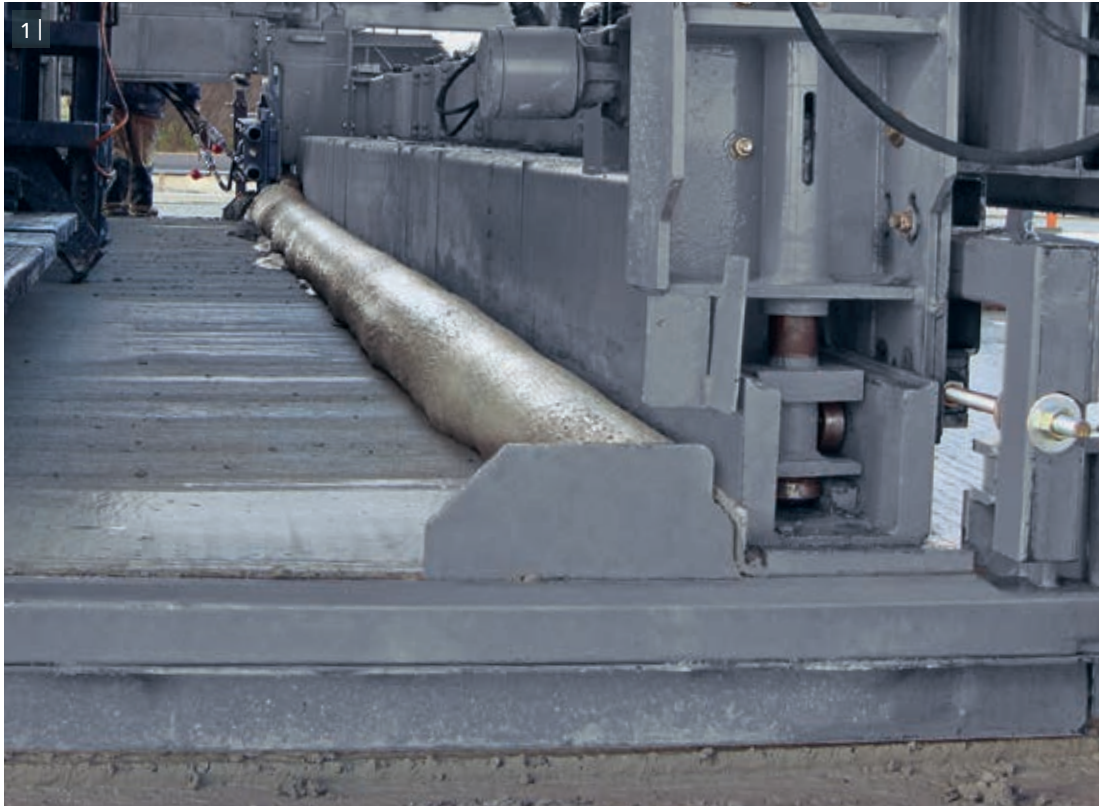

1 | The heavy-duty oscillating beam produces an even surface.

2 | The super smoother manufactured from high-quality material produces a perfectly smooth surface finish.

3 | The hydraulically adjustable sideplates minimize concrete losses and produce high-quality concrete edges.



Effective concrete curing

SKID-RESISTANT SURFACE, OPTIMIZED HARDENING

The skid resistance of road pavements is a major contributor to traffic safety. In accordance with national or tender specifications, WIRTGEN texture curing machines can be used to produce different grip values generating different noise levels. To do so, a plastic or metal broom is applied, moving over the concrete slab in either transverse, diagonal or longitudinal direction. As an alternative to the broom finish, burlap or artificial turf is guided across the concrete slab in longitudinal direction. Exposed aggregate concrete is increasingly applied as an alternative technology.

Depending on weather conditions and paving result, dispersion must additionally be sprayed on the fresh concrete surface as quickly as possible to prevent premature drying. WIRTGEN texture curing machines offer solutions for transverse and longitudinal spraying: for transverse spraying, a carriage fitted with spray nozzles moves across the full working width in transverse direction while simultaneously applying the broom finish. Alternatively, a spray bar fitted with spray nozzles applies the dispersion as the machine advances. If spraying only is required, the time-saving "meander spraying" feature can be used to apply the dispersion in a meandering pattern while the machine keeps driving forward.



1 |



1 | A burlap drag finish gives the concrete surface a fine-grained texture.

2-3 | The texture curing machine creates a defined texture, for example, by applying a broom finish while spraying dispersion at the same time.



2 |



3 |

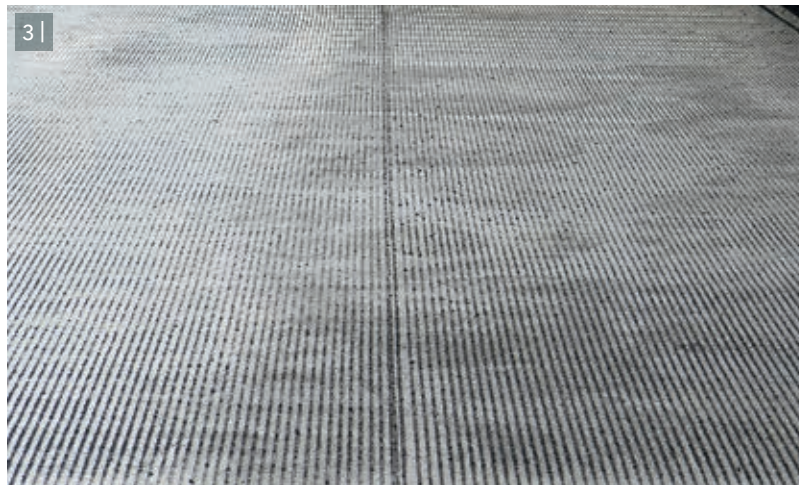



The WIRTGEN AutoPilot steers the machine with maximum precision to produce high-quality paving results.

Intelligent machine control systems

PRECISION IN PAVING GUARANTEED

WIRTGEN offers a variety of different machine control systems. By scanning a stringline using WIRTGEN sensors, for example, the control system generates highly precise level and steering parameters for the slipform paver.

When using an external 3D system, digital topographic data are reconciled with the positioning data of the machine located by a total station. Any deviations from the specified position are processed by the 3D control interface to generate precise level and steering corrections, thus ensuring highly precise driving behaviour.

Yet another option is the AutoPilot, a control system developed in-house. It also requires a geodetic data model which is either imported or created on site using the Field Rover prism pole. The AutoPilot uses these data to calculate a precise virtual stringline which provides the slipform paver with the required level and steering parameters. The AutoPilot thus replaces the stringline and is a time-efficient option which allows flexible use in accordance with site conditions.



1 | The specifications provided by the stringline are translated into concrete slabs paved to maximum accuracy.

2 | 3D: flexible positioning of the total station dispenses with the need to tension a stringline.

3 | The Field Rover is used to collect measuring points and perform final inspection.



Machine setup adapted to restricted space conditions.

Professional expertise for complex paving operations

SLAB TRACK AND TUNNEL CONSTRUCTION

WIRTGEN has been a key driver in developing the so-called "slab track" construction method. When paving a slab track, the slipform paver produces a concrete slab with a specific cross-section that needs to adhere to requirements with pinpoint precision. A slab track can be produced in a virtually limitless variety of cross-sections and serves as a stable foundation for high-speed trains – a means of transport playing an increasingly important role. High-speed trains generate extremely high forces acting on the track system, which is why the railway tracks are embedded in concrete

rather than in standard track ballast. Compelling marks in favour of the ballastless type of construction are durability, strength, precise track position, reduced noise emissions and ease of maintenance.

WIRTGEN has many years of experience also in paving concrete floors in tunnels where space is extremely limited. In such projects, the machine setup is customized to precisely fit these specific, challenging application requirements.



1 | Concrete slabs paved to maximum precision enable train speeds in excess of 300 km/h.

2 | Precision in operation for regional rail transport or high-speed trains.

3 | Zero-clearance paving below ground using stringless control.



PRODUCT PORTFOLIO CATERING TO ALL STANDARD AND SPECIAL APPLICATIONS

The comprehensive product portfolio of WIRTGEN inset slipform paver models covers all performance classes and fields of application. In addition, concrete paving kits are available in metric or imperial dimensions to cater to specific applications and customer requirements. Standard paving widths for concrete slabs range from 1.0 m to 16.0 m at standard paving thicknesses of up to 450 mm. We also supply state-of-the-art solutions for the dual-layer “wet-in-wet” paving process. To complement the extensive range of inset slipform pavers, WIRTGEN offers side feeders and texture curing machines. The comprehensive portfolio of WIRTGEN slipform pavers for offset paving applications enables a wide variety of different machine configurations. Concrete safety barriers for impact protection on motorways can be produced at standard heights of up to 2.2 m.

A winning team of pavers

covering all working widths.



SP 15



SP 15i



SP 25i



SP 25i



SP 500



SP 61



SP 61i



SP 62



SP 62i



SP 64



SP 64i



SP 92



SP 92i



SP 94



SP 94i



SP 1200



SP 1500



SP 1500 L



SP 1600



TCM 95



TCM 95i



TCM 180



TCM 180i



ISF 94



ISF 94i



The specialized knowledge gained in the production of several hundred small and large slipform pavers feeds directly into the manufacturing process.

State-of-the-art production of durable machines

WE PUT QUALITY FIRST

Mature manufacturing processes, production expertise, fully customized products, extensive quality testing, a high degree of autonomy for our employees - these are the cornerstones of WIRTGEN's slipform paver production hub in Windhagen. These standards are reflected in the state-of-the-art, partially computer-controlled manufacturing equipment, high degree of vertical integration and highly qualified workforce. In-house production of a large number of customized options and special

components enables us to offer most diverse customer-specific equipment combinations. Reliable operation and a long machine life are ensured by the use of high-quality materials.

Our success proves us right: each single machine leaving our production facility is of superior quality.

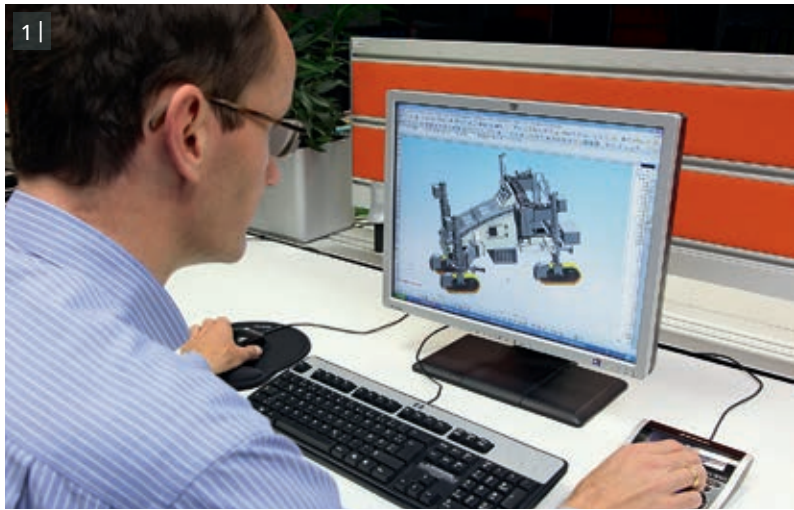

1 | State-of-the-art hardware and software are the "tools of trade" of our engineers and technicians.

2 | The machines are assembled by highly qualified expert staff.

3 | High-quality welding work - as on the machine frame shown here - is an important part of the production process.

Worldwide customer service makes the difference

INDUSTRY EXPERTS APPRECIATE OUR CUSTOMER FOCUS

We at WIRTGEN combine perfectly engineered and innovative technologies with an extensive global service network of highly proficient subsidiaries, sales partners and dealers. This winning combination provides our customers with real added value - around the globe, around the clock. For our customers, optimum service reads: short delivery times for machines, spare parts and wearing parts as well as comprehensive parts inventories, qualified consulting and support services, demonstrations by qualified local personnel and trainings at the customer's location.

Fully qualified WIRTGEN service engineers accompany and support operations at the customer's request. Our service engineers are specialists, fully equipped with state-of-the-art tools and fully familiar with the entire WIRTGEN product portfolio. They can be contacted around the clock, guaranteeing the prompt delivery of parts on order.

Fully qualified WIRTGEN service engineers accompany and support operations at the customer's request.



1 | Around the globe, mobile service engineers are on location in the shortest possible time.

2 | Spare parts are available at our subsidiaries immediately and in large quantities.

3 | In training courses, WIRTGEN training pros impart lots of specialized knowledge on everything to do with the machines, technologies and processes.



Wirtgen slipform pavers conquer the world

36
37



SUCCESSFUL MARKET EXPANSION AROUND THE GLOBE

Following acquisition by WIRTGEN, it doesn't take long for the technology to bear the hallmark of a world-leading construction equipment manufacturer. For the slipform paver business is quick in conquering the world market: a large regular clientele is established not only in Central Europe but also in Eastern Europe and in numerous countries across Asia. In recent years, our machines have found a ready market also in North America. WIRTGEN slipform pavers are in operation in all parts of the world, having earned their merits in particular on account of their exceedingly long service life: quality "made in Germany" is a trademark.



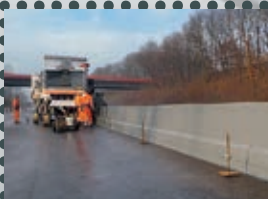

ENVIRONMENTALLY FRIENDLY MACHINE TECHNOLOGY

WIRTGEN has expressly committed to protecting the environment, to manufacturing safe, environmentally friendly machinery and to developing ecologically sustainable technologies and products.

Slipform pavers are energy-efficient machines with low fuel consumption and correspondingly low exhaust emission rates. Slipform pavers, in turn, produce durable concrete pavements and poured-in-place concrete profiles. The long period from new construction to rehabilitation or reconstruction greatly benefits the environment from an ecological viewpoint: its positive effects are lower emission levels, reduced energy requirements and the non-use of valuable resources. The process minimizes disruptions to traffic, thus making a further contribution to protecting the environment. Due to their low rolling resistance, concrete pavements benefit fuel economy.

State-of-the-art engine technology and the innovative machine management system reduce exhaust and noise emissions. Effective soundproofing and the anti-vibration mounted engine ensure low noise and vibration levels.

**We face up to the challenge
of environmental protection.**





WIRTGEN GmbH

Reinhard-Wirtgen-Str. 2 · 53578 Windhagen · Germany
Phone: +49 (0)26 45/131-0 · Fax: +49 (0)26 45/131-392
Internet: www.wirtgen.com · E-Mail: info@wirtgen.com

